

Steambath Generator

Model: SM-11

The Steamist "SM" Generator operates with one or two controls appropriately located inside and/or outside the steamroom. It's small enough in size to be tucked away using very little space in a vanity, closet, basement, or an insulated attic, but large enough to provide steam for most residential baths.

The Steamist "SM" Steambath Generator comes factory assembled, carefully wired and tested.

NOTE: The SMC-120, SMC-150, TC-125, TC-150, TC-110, TC-135, DSC-425, and DSP Controls are designed to work with all Steamist "SM" Generators.

1. Pre-Installation

- Proper electrical supply (208 or 240 Volt): See rating label on Steam Generator and Chart on back page. Determine proper size of wire, voltage, amperage, and phase for the Steam Generator. Only UL rated 90°C wire can be used.
- Dedicated overcurrent protection device, such as an in-line fuse/circuit breaker required: Fuse/circuit breaker to be installed must be sized in accordance with chart on back page. Do NOT install a GFI (Ground Fault Interrupter) to this equipment (per article 210-8 in the National Electric Code).
- Route power supply cable to the location where the Steam Generator will be installed (before walls are closed).

2. Electrical Rough-in

- At this time read through the installation instructions for the selected control(s).
- Route appropriate power cable to the location the Steam Generator will be installed. If receptacle is desired, mount the box for the receptacle near the location of the Steam Generator (see Figure 3: Typical Installation).

NOTE: The plug and receptacle require a rating of no less than 250V and proper amperage. Refer to chart on page 4 for amperage rating.

After the walls are complete, the Steam Generator and Control can be wired.

3. Steam Generator Electrical Installation

WARNING: All power to the Steam Generator must be turned off.

- Remove the two screws holding the electrical access cover and remove cover.
- Locate the supply line knockout. Mount proper strain

relief into knockout hole (see Figure 2: Internal Electrical Connections).

- Strip back power cable's outer insulation jacket eight inches and insert into Steam Generator. Strip back insulation ½" from the three (3) incoming wires (two power and one ground).
- Connect incoming ground wire to floating green pigtail labeled "GND."

CAUTION: Be sure the ground wire does not come in contact with a live electrical part.

- Connect incoming power to floating black pigtail leads labeled "L1" and "L2" (see Figure 2: Internal Electrical Connections).
- The Steam Generator is ready for operation once the installation of the controls is completed (refer to separate Installation and Operating Instructions).

4. Optional Auto Drain Valve Connection

- Open knockout for Auto Drain Valve conduit connection.
- Route flexible conduit from valve to knockout and secure.
- Connect two wires from valve to the two place terminal strip provided (see figure 2).

Figure 1 - Steam Generator

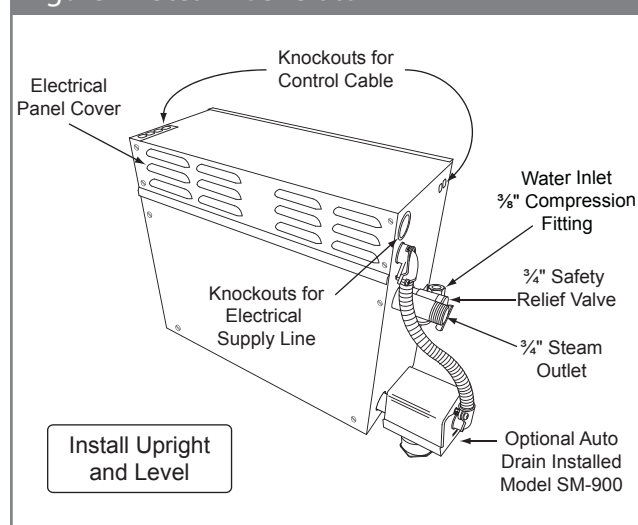

WARNING: Elderly persons, pregnant women, or those suffering from heart disease, high blood pressure, diabetes, or who are otherwise not in good health, do not use this device unless directed to do so by a physician. Also, do not use steambath while under the influence of alcohol. For additional Important Safety Information, please see a separate instruction Pub. No. 199.

IMPORTANT: The warranty of this product is voided if it is used in a commercial application or for anything other than a residential steambath installation. All electrical connections must be performed by a licensed electrician in accordance with Local and National Electric Codes. This product is not intended for use with Home Automation systems.

Checklist

Model: SM-11

Before starting, insure that the conditions of the following checklist have been met:

- The proper size Steam Generator has been selected by using the sizing page in the "Full Line Brochure," "Pricing Guide," or "The Generator Sizing Guide" in the Residential Systems/Steambath Product Information section of the Steamist website - www.steamist.com.
- CAUTION:** An improperly sized Steam Generator will NOT produce the amount of steam necessary to reach selected temperature.
- The proper voltage Steam Generator has been selected (i.e., 208V or 240V). A 208V Generator operating on 240V will damage the heating element, and a 240V Generator operating on 208V will result in a 25% loss of power.
- The Steam Generator is installed in an upright position.
- The proper sized 90°C wire and circuit breaker have been used.
- The circuit breaker is NOT a GFI (Ground Fault Interrupter) type.
- The Steam Generator is properly grounded.
- The circuit breaker or disconnect switch is on.
- Water supply is open to the Steam Generator.

Figure 2 - Major Electrical Components

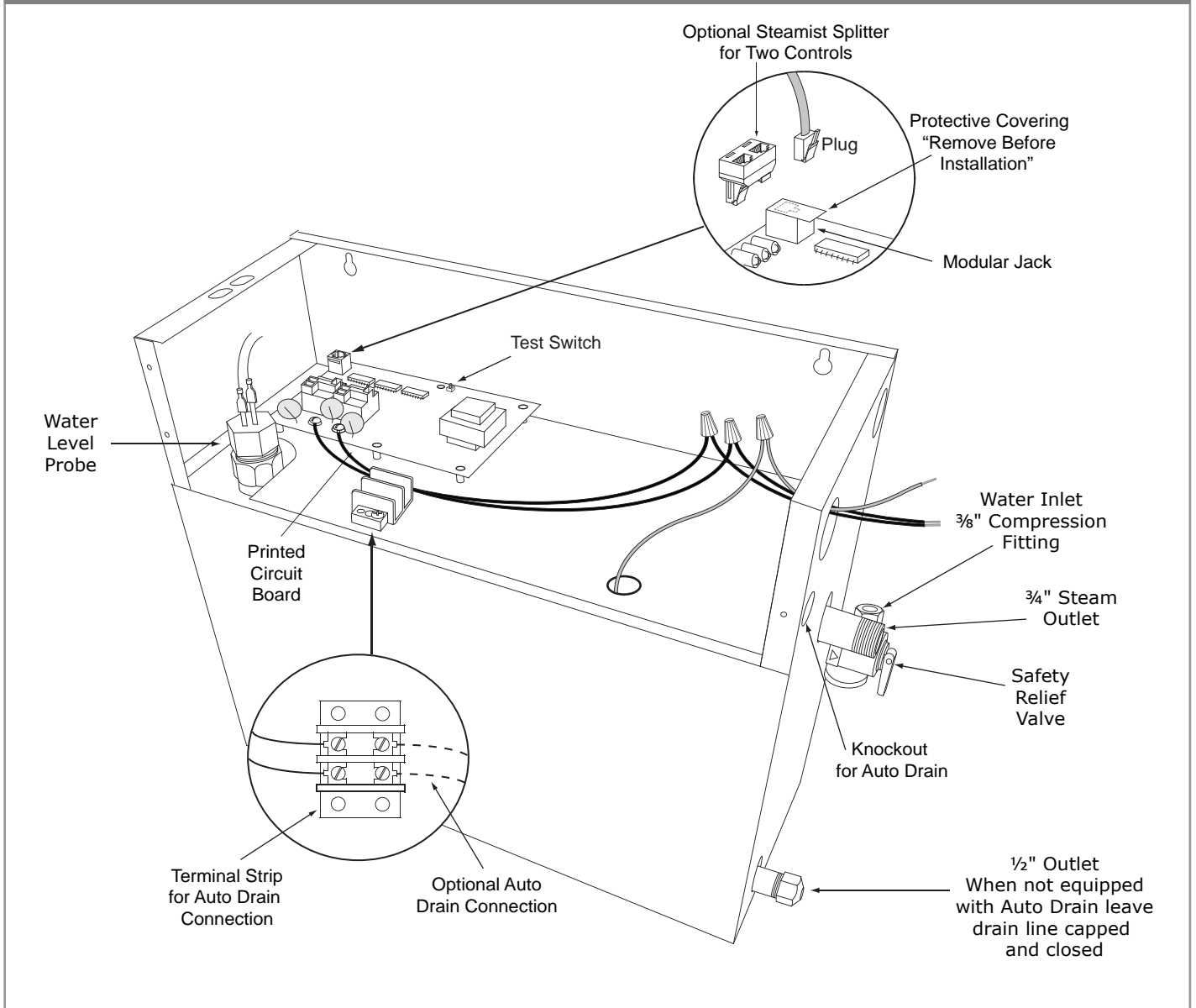

Figure 3 - Typical Installation

Model: SM-11

The Electrical Instructions must be given to the homeowner for future use.

NOTE: Unit must be wired with 90°C wire in a suitable raceway, or, if local codes allow, provide twist lock plug on a 90°C wire cord from generator to a 250V 2-pole, 3-wire grounding receptacle (amperage rating as required).

SMC-120 or TC-125
Auxiliary Outside
Control

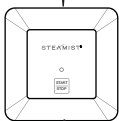

Control Cable
Route from
Control to Steam
Generator in a
3/4" conduit.

Appropriately
fuse protected
208/240V field
wiring to Steam
Generator.

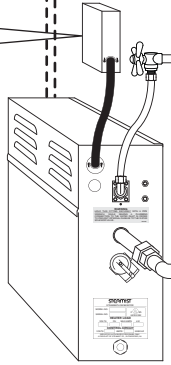

Inside Installation
Control should be mounted four feet from the floor. Select a location convenient to the bather but not in a direct line of Shower or Body Sprays and not directly above the Steamhead.

SMC-150 or TC-150
Control **MUST** be
installed inside the
steam room.

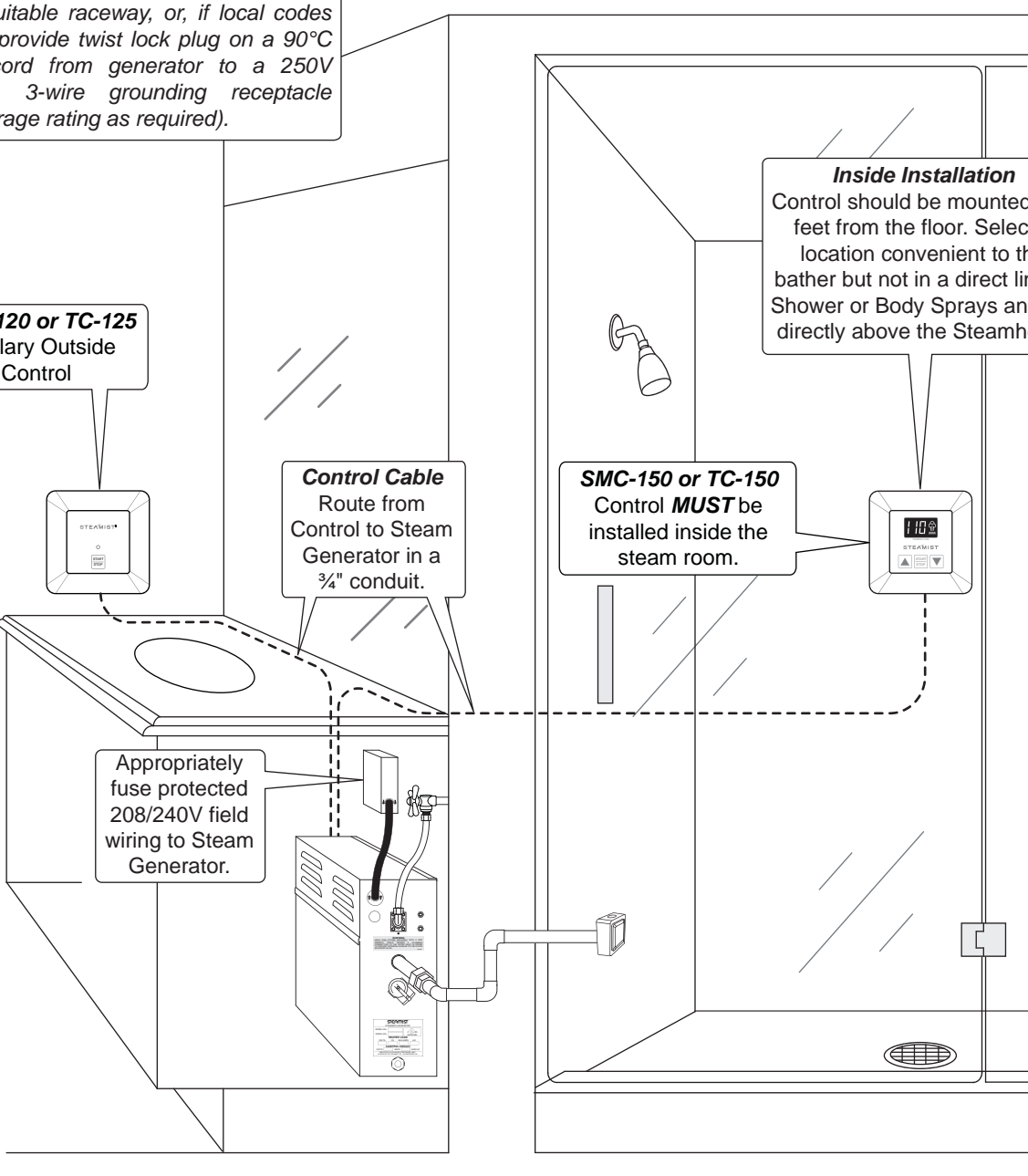
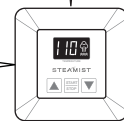

IMPORTANT: Run the Control Cable through a 3/4" conduit. Remove protective cap when making the final connection to Control.

240/208 Volt Single Phase Schematic

Model: SM-11

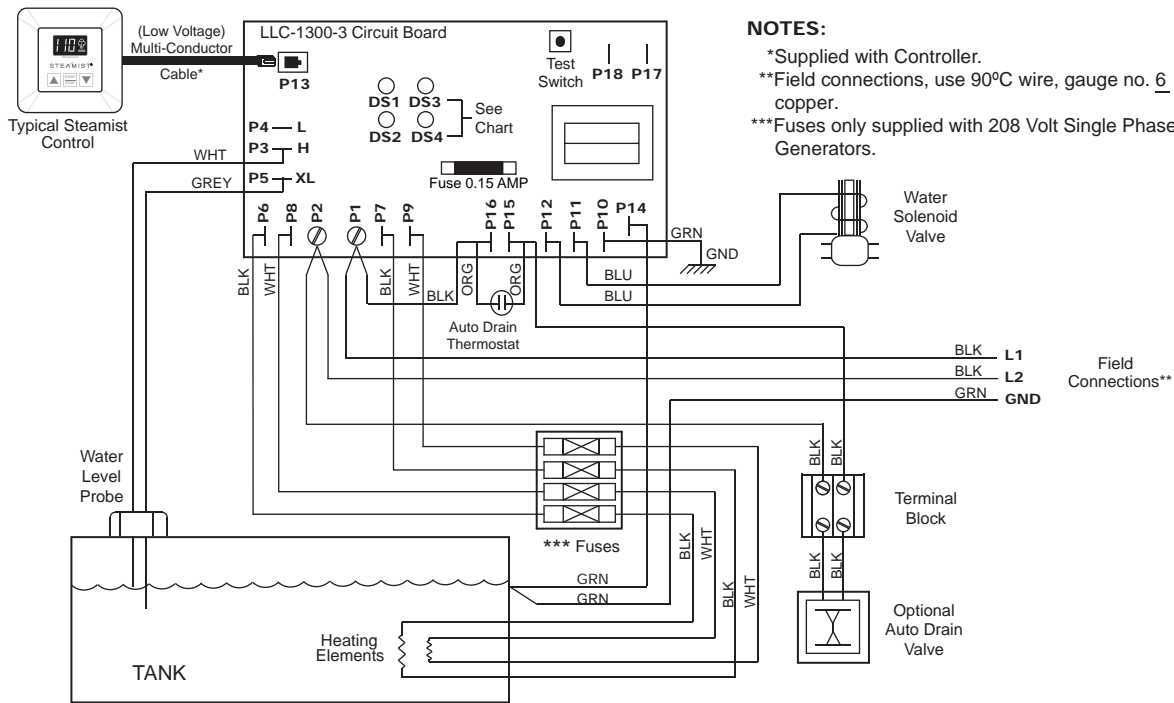

240/208 Three Phase Schematic

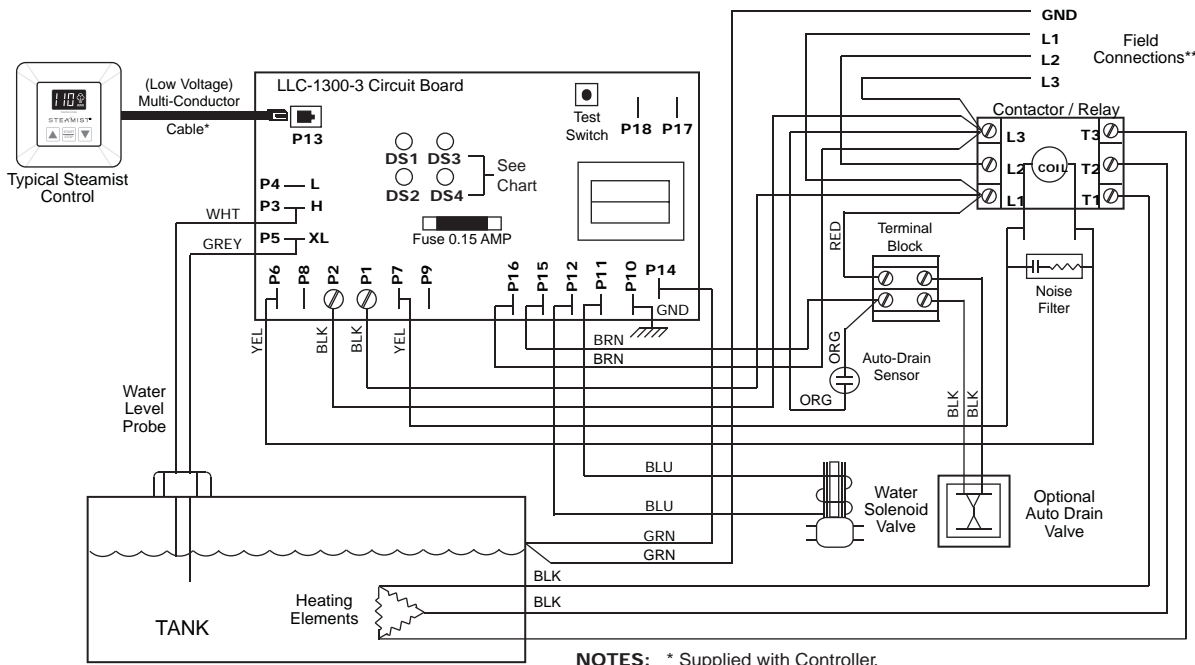

Specification Chart

Model No.	Max. Cu. Ft. For Area Up To	KW	Volt	Phase	Amps	*Wire Size 90°C Copper AWG	Line Fuse
SM-11	400	11	240	1	46	6	60
			208	1	53	6	70
			240	3	27	8	35
			208	3	31	8	40

* NM-B type cable does not follow the 90°C wire guideline. The NEC requires NM-B type cable max current to be de-rated. Always follow local and national electrical codes.

LED Color Chart

DS1	GRN	TIMER ON
DS2	YEL	HEAT ON
DS3	AMB	WATER FILL ON
DS4	RED	POWER ON

Steambath Generator

Model: SM-11

The Steamist "SM" Generator comes factory assembled, carefully wired and tested.

WARNING: All electrical power should be turned OFF when working with Steam Generator.

IMPORTANT: The Plumbing Installation must conform to local and national codes.

1. Pre-Installation

- a) Be sure that the proper size Steam Generator has been selected by using the sizing page in the "Full Line Brochure," "Pricing Guide," "The Generator Sizing Guide," "Architectural Guidelines," or in the Residential Systems/Steambath Product Information section of the Steamist website - www.steamist.com.

CAUTION: An improperly sized Steam Generator may NOT produce the amount of steam necessary to reach selected temperature.

IMPORTANT: Refer to page 4 for model required for cubic foot rating.

- b) The Steam Generator should be located as close as possible to the Steamroom/Shower or tub enclosure. Steam pipe should NOT exceed twenty-five feet in length. If the steam pipe exceeds ten feet, use an appropriate pipe insulation rated for a minimum of 212°F. Possible locations include Vanity, Closets, Attic (insulated), or Basement near bath area. The serial number plate should be visible and the Steam Generator should be accessible for service. Refer to Installation Suggestions on page 4. Do NOT install Generator outdoors, in a moist, humid area, or in an area where parts may freeze or corrode. Also, do NOT install near flammable materials such as paints, thinners, gasoline, etc.
- c) The steam line and safety valve reach a temperature of 212°F during operation and should be appropriately protected to prevent personal injury by accidental contact.

2. Plumbing Rough-in

Plumbing rough-in is required for the water supply and steam line; this should be completed before the walls are closed. For operation, the "SM" Steam Generator requires a $\frac{3}{8}$ " O.D. copper tubing to the fitting on the generator for water inlet and a $\frac{3}{4}$ " copper or brass pipe for steam outlet.

NOTE: Safety Valve should be connected to a minimum $\frac{3}{4}$ " indirect waste or as required by local plumbing codes. In the unlikely event this valve should open, the discharge must be directed to prevent damage to the home. Do NOT connect the Safety Valve output to the steam line.

- a) **Water Inlet** - Rough in a water line to the hot or cold supply. A shut off valve with a $\frac{3}{8}$ " connection to the steam generator is to be provided at the generator location (see Figure 4 on page 3).
- b) **Steam Outlet** - Rough in the steam line using a minimum of a $\frac{3}{4}$ " copper or brass pipe; do NOT use black iron or galvanized pipe, it will rust and discolor the wall of the steambath. The steamhead location should be 18" above the shower floor or 6" above the rim of the bathtub, as far from the seating area as possible. Also, do NOT use plastic type water lines as a steam line.

CAUTION: No shutoff valve can be installed in the steam line. Do NOT create traps or valleys in this line which would trap condensation and block the flow of steam. The steam pipe should be pitched toward the Steam Generator allowing condensation to run back toward the Steam Generator (preferred), or toward the steamhead. If the steam generator is equipped with a drain valve, do NOT connect the drain pipe to the steam line.

Figure 1 - Steam Generator

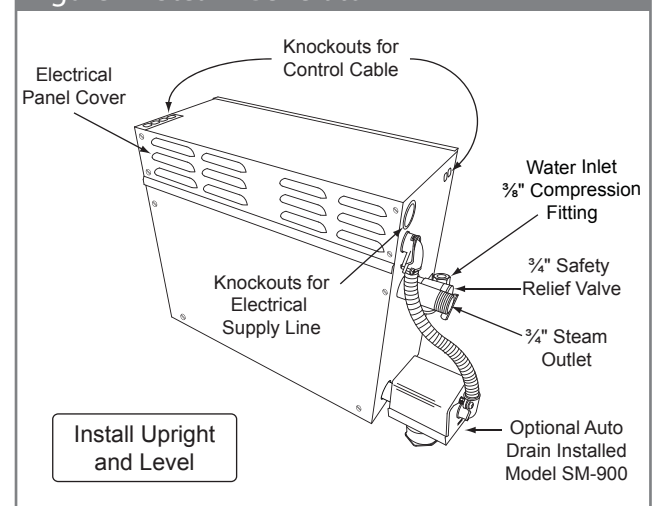

WARNING: Elderly persons, pregnant women, or those suffering from heart disease, high blood pressure, diabetes, or who are otherwise not in good health, do not use this device unless directed to do so by a physician. Also, do not use steambath while under the influence of alcohol. For additional Important Safety Information, please see a separate instruction Pub. No. 199.

IMPORTANT: The warranty of this product is voided if it is used in a commercial application or for anything other than a residential steambath installation. This product is not intended for use with Home Automation systems.

3. Steam Generator Installation

The Steam Generator should be mounted in a location convenient for hook-up and service by the plumber and electrician.

CAUTION: The Steam Generator is designed to be used ONLY in an upright and level position; to do otherwise would damage the unit and void the warranty.

- a) The Steam Generator can be mounted to a wall or set on the floor. However, the unit must be secured. To secure the unit to a vertical wall, loosen the two screws holding the electrical access cover, remove cover (see Figure 1). Located inside the cabinet near the top left and right corners are mounting holes. Place top cover back and secure.
- b) Connect the $\frac{3}{8}$ " water inlet to a shut off valve as described in Section 2.a. The valve must be kept in an open position during normal operation. In an area where water hammer is a problem install a water hammer arrestor in the line. Refer to Figure 2.

IMPORTANT: Do NOT use a "saddle valve" or piercing type valve for water connection.

- c) Connect the steam line from rough-in location described in Section 2 to the $\frac{3}{4}$ " nipple on the Steam Generator using a union.

Figure 2 - Plumbing Diagram

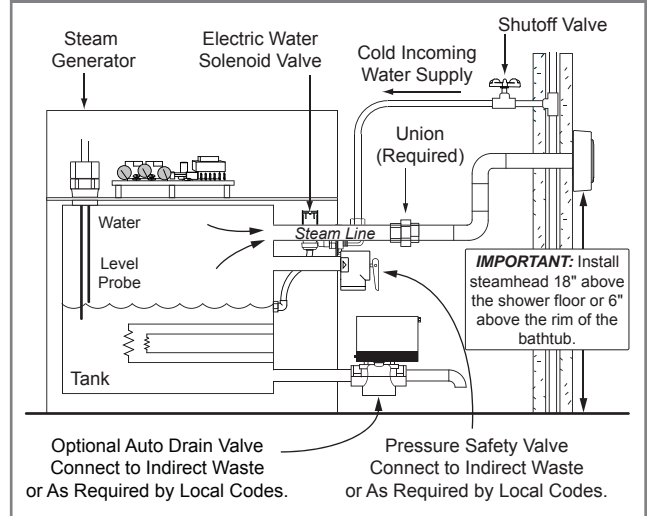

3199 Series Steamhead Installation Instructions

1. Make sure the $\frac{3}{4}$ " nipple protrudes beyond the tile approximately $\frac{1}{2}$ ". (See Figure 3)
2. Wrap the nipple with pipe sealant tape.
3. Put a bead of silicone around the outer edge of the Back Plate (see Figure 3) and center the Back Plate over the pipe in an upright position. While holding it in place, screw the Center Hub onto the nipple, using a $\frac{3}{8}$ " hex key to tighten.
4. The Center Hub MUST be aligned with the four walls in the vertical and horizontal position (See Figure 3a). Make sure the steamhead O-ring is fully seated into the Back Plate.
5. Apply a small amount of silicone at the back center point of the Cover Plate. This will aid in preventing movement of this plate. (See Figure 3a)
6. Place the Cover Plate over the Center Hub. This is accomplished by first hooking the top and then snapping the bottom into place.
7. Adjust the Back Plate and Cover Plate to line up squarely, and clean excess silicone with rubbing alcohol.

Figure 3 - Steamhead Installation

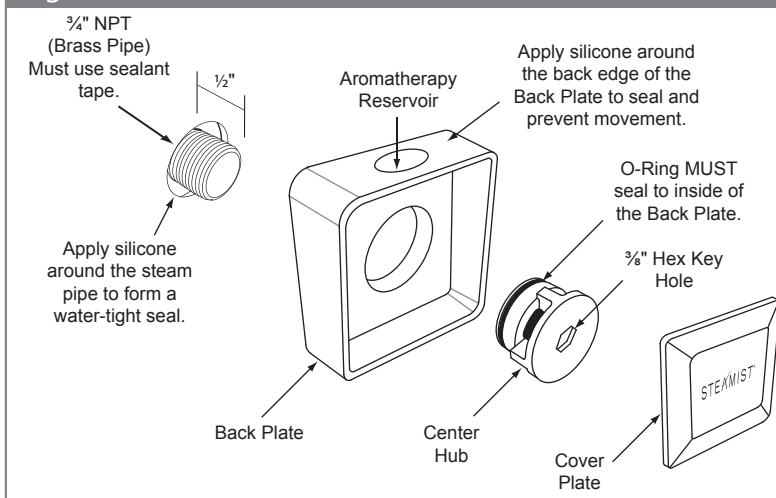

Figure 3a - Center Hub Installation

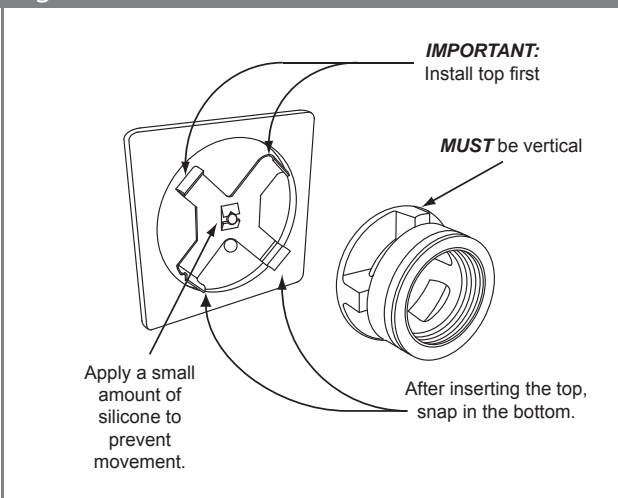
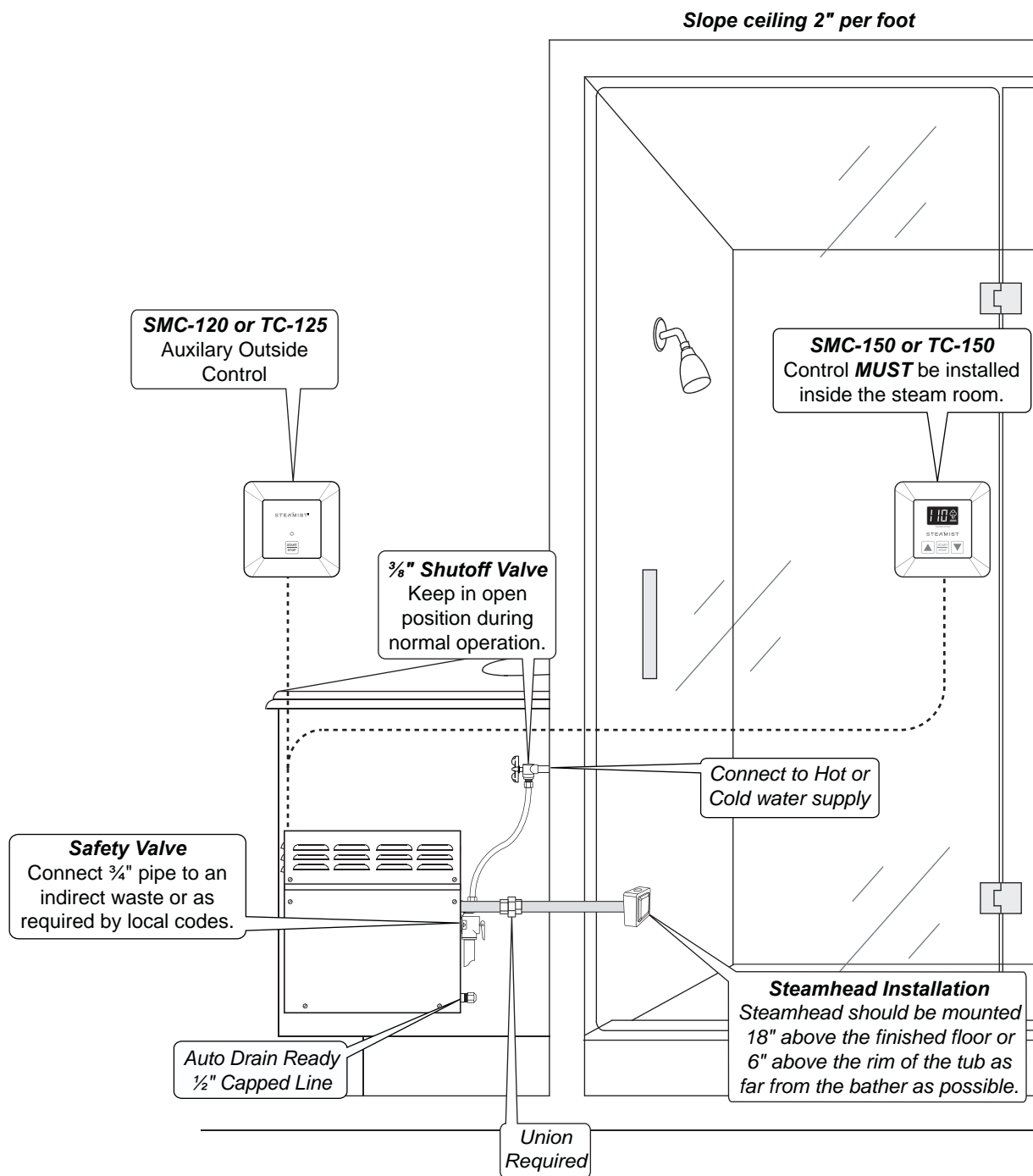

Figure 4 - Typical Installation

Model: SM-11

The Plumbing Instructions must be given to the homeowner for future use.



Steam Outlet Pipe - Use a minimum of a 3/4" Copper or Brass pipe.

NOTE: The SM Series steam generators will also work with the following controls: TC-110, TC-135, DSC-425, and DSP.

CAUTION: Do NOT install a shutoff valve on the steam outlet pipe. Do NOT create traps or valleys in this line which would prevent the flow of steam. The steam outlet pipe should be pitched toward the Steam Generator (preferred), allowing condensation to run back into the Steam Generator or toward the steamhead. If the steam pipe exceeds ten feet, use an appropriate pipe insulation rated for a minimum of 212°F.

Access Requirements

Model: SM-11

Select a location for mounting the Steam Generator that is accessible for installation and service. The access requirement indicates the minimum space for convenient access to Steam Generator.

CAUTION: All models must be installed INDOORS, in a DRY, NON-FREEZING location away from flammable materials such as: Gasoline, Paints, Thinners, Etc.

NOTE: This steam generator is NOT intended to be used for space heating purposes.

IMPORTANT: Steam Generator must be installed upright and level.

Specification Chart

Model No.	*Max. Cu. Ft. For Area Up To	KW	Volt	Phase	Amps	**Wire Size 90°C Copper AWG	Line Fuse
SM-11	400	11	240	1	46	6	60
			208	1	53	6	70
			240	3	27	8	35
			208	3	31	8	40

* Refer to the Steamist Sizing Guide for actual Cu. Ft. capacity.

** NM-B type cable does not follow the 90°C wire guideline. The NEC requires NM-B type cable max current to be de-rated. Always follow local and national electrical codes.

Figure 5

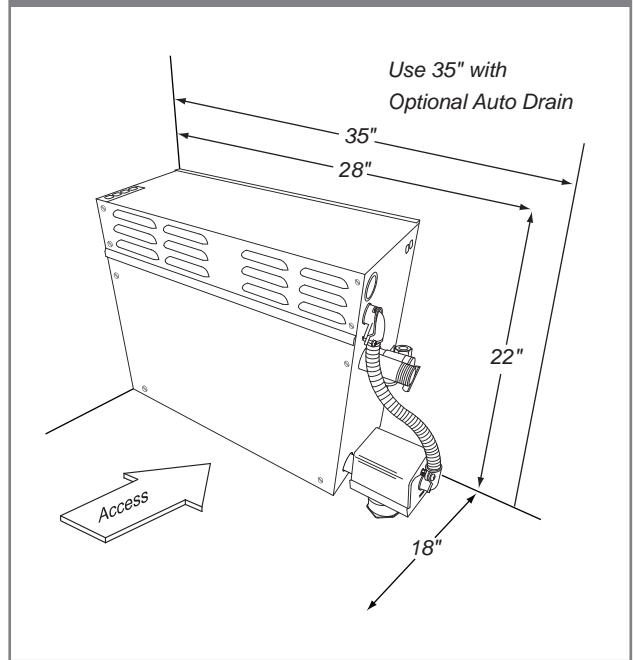

Installation Suggestions

